

I SERRAMENTI SONO COSTRUITI CON PROFILATI ESTRUSI IN LEGA EN AW 6060-T6. LE DIMENSIONI INDICATE SUI DISEGNI DEI PROFILATI SONO TEORICHE, POTRANNO QUINDI VARIARE IN FUNZIONE DELLE TOLLERANZE DIMENSIONALI DI ESTRUSIONE NORMA EN 755-9. LA SEZIONE ESTERNA DEI PROFILATI PER TELAI FISSI È DI 54 MM, QUELLA DELLE ANTE MOBILI È DI 32 MM. LA DIMENSIONE DEL VANO PER L'INSERIMENTO DELLA SQUADRETTA, SIA PER I TELAI FISSI CHE PER QUELLI APRIBILI, È DI 25 MM X 11 MM (MISURA INTERNA).

L'ALETTA DI BATTUTA INTERNA SUL MURO È DI 20 MM, L'ALTEZZA DELLA SEDE PER IL VETRO È DI 17,4 MM. LA TENUTA DEL SISTEMA ALL'ARIA E ALL'ACQUA È GARANTITA DA UNA DOPPIA GUARNIZIONE A SPAZZOLINO INSERITA PERIMETRALMENTE NEI PROFILATI DELLE ANTE MOBILI E IN APPOGGIO SUI BINARI DEI TELAI FISSI. I SERRAMENTI POSSONO ESSERE COSTRUITI CON TELAI A DUE O TRE BINARI E UTILIZZARE NEL NODO CENTRALE DELLE ANTE SCORREVOLI PROFILATI RINFORZATI PER AUMENTARNE LE DIMENSIONI DI IMPIEGO. SUL TRAVERSO INFERIORE DEL TELAIO FISSO SARANNO EFFETTUATE DELLE ASOLE PER IL DRENAGGIO DELL'ACQUA, MENTRE SUL TRAVERSO INFERIORE MOBILE SI PUNZONERANNO ALTRE ASOLE PER L'AREAZIONE DEL VANO VETRO QUANDO SARANNO USATI VETRI-CAMERA.

GLI ACCESSORI SONO DI FACILE E RAZIONALE APPLICAZIONE ACCOGLIENDO TUTTI QUELLI NORMALMENTE IN COMMERCIO DIMENSIONATI E COLLAUDATI A TALE USO.

THE FRAMES ARE MANUFACTURED WITH EN AW 6060-T6 ALLOY EXTRUDED STRUCTURAL STEEL. THE DIMENSIONS SHOWN ON THE STRUCTURAL STEEL DRAWINGS ARE THEORETICAL AND SUBJECT TO CHANGES BASED ON DIMENSIONAL EXTRUSION TOLERANCES ACCORDING TO THE EN 755-9 STANDARD. THE OUTSIDE STRUCTURAL STEEL SECTION FOR FIXED FRAMES IS 54 MM, WHEREAS THAT OF MOVING WINGS IS OF 32 MM. THE SQUARE HOUSING DIMENSIONS ARE MM 25 X 11 (INSIDE SIZE) FOR BOTH FIXED AND OPENING FRAMES.

THE INSIDE WALL STOP TONGUE IS 20 MM; THE GLASS SEAT HEIGHT IS 17,4 MM. THE AIR AND WATER-TIGHT SYSTEM IS MADE UP OF A DOUBLE BRUSH SEAL ARRANGED EXTERNALLY IN THE MOVING WING STRUCTURAL STEEL AND RESTING ON THE FIXED FRAME TRACKS. THE FRAMES CAN BE MANUFACTURED WITH TWO OR THREE TRACKS; STIFFENED STRUCTURAL STEEL MAY BE USED IN THE SLIDING WING CENTRAL JOINT TO INCREASE THE USEFUL DIMENSIONS. WATER DRAINAGE SLOTS WILL BE MADE ON THE BOTTOM TRANSOM OF THE FIXED FRAME, WHEREAS GLASS SPACE AERATION SLOTS WILL BE PUNCHED ON THE BOTTOM MOVING TRANSOM WHEN DOUBLE GLAZING IS USED.

THE ACCESSORIES ARE EASY TO FIT, AS THE SYSTEM CAN SEAT ALL ACCESSORIES USUALLY AVAILABLE ON THE MARKET, SIZED AND TESTED TO THIS PURPOSE.

zn7-32001 pag. 6

gr/m 1003
Jy cm⁴ 12.3
Wy cm³ 4.3

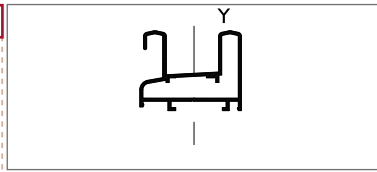

zn7-32010 pag. 7

gr/m 446

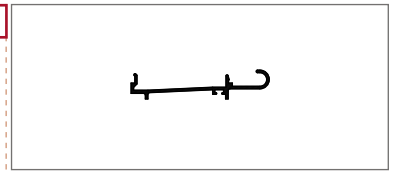

zn7-32002 pag. 6

gr/m 1084
Jy cm⁴ 14
Wy cm³ 4.6

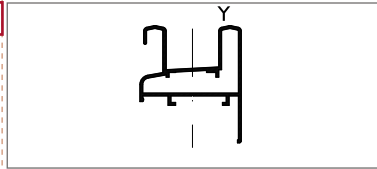

zn7-32015 pag. 7

gr/m 944
Jy cm⁴ 6.1
Wy cm³ 3.8

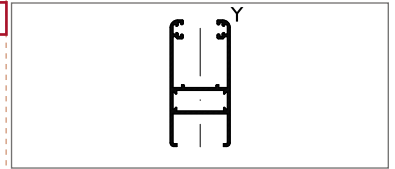

zn7-32003 pag. 6

gr/m 1224
Jy cm⁴ 23.9
Wy cm³ 6.2

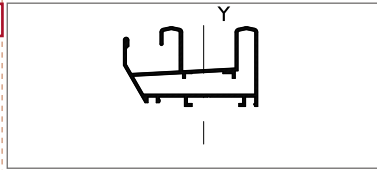

zn7-32016 pag. 7

gr/m 1342
Jy cm⁴ 18.7
Wy cm³ 5.3

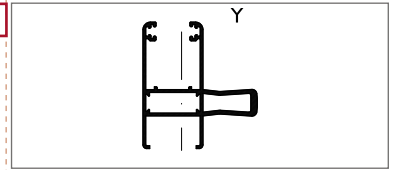

zn7-32004 pag. 6

gr/m 1291
Jy cm⁴ 25.3
Wy cm³ 6.7

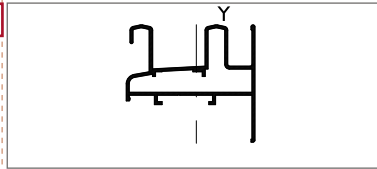

zn7-32021 pag. 7

gr/m 351

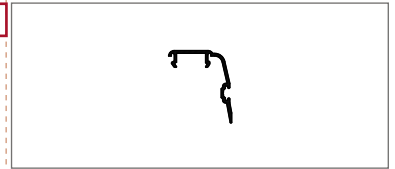

zn7-32005 pag. 6

gr/m 1621
Jy cm⁴ 54
Wy cm³ 11

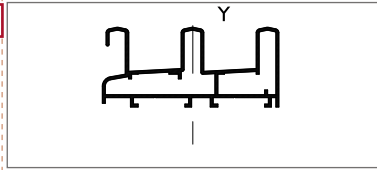

zn7-32025 pag. 7

gr/m 228

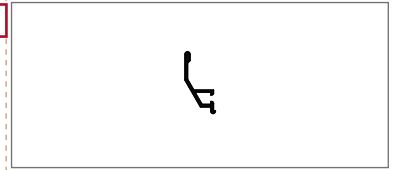

zn7-32006 pag. 8

gr/m 577

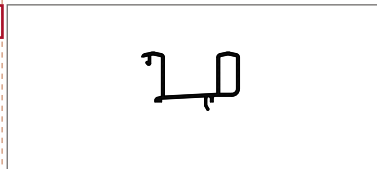

zn7-32030 pag. 8

gr/m 1128
Jy cm⁴ 12.2
Wy cm³ 4.2

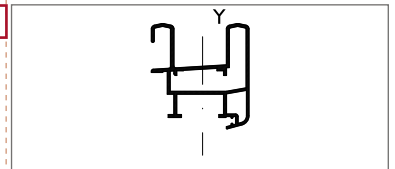

zn7-32007 pag. 8

gr/m 585

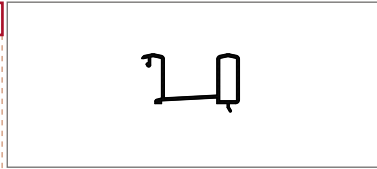

zn7-32031 pag. 9

gr/m 906
Jy cm⁴ 10.5
Wy cm³ 3.5

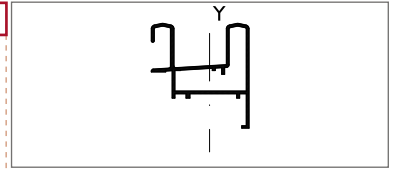

zn7-32008 pag. 9

gr/m 615

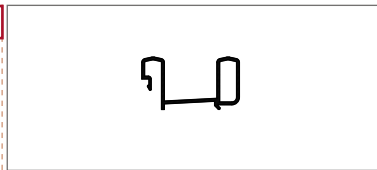

zn7-32032 pag. 8

gr/m 1114
Jy cm⁴ 12.4
Wy cm³ 4.3

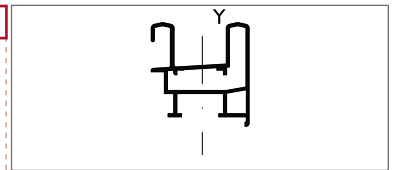

zn7-32009 pag. 9

gr/m 622

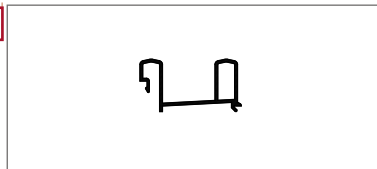

zn7-32033 pag. 9

gr/m 900
Jy cm⁴ 10
Wy cm³ 3.5

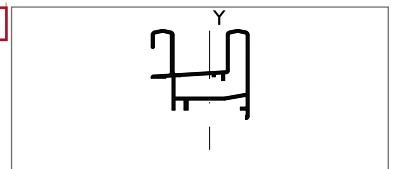

	pag.	
zn7-32035 gr/m 959 Jy cm ⁴ 11.3 Wy cm ³ 4.1	9	
zn7-32037 gr/m 910 Jy cm ⁴ 9.88 Wy cm ³ 3.45	8	
G56 gr/m 1033 Jy cm ⁴ 4.9 Wy cm ³ 3.5	7	
G87 gr/m 251	7	
G91 gr/m 225	7	

S

I

S

E

H

T

Z

Y

S

LIMITI D' IMPIEGO - LIMITS OF USE

FRECCIA MASSIMA - MAXIMUM CAMBER: 1/200

ZN7-32015

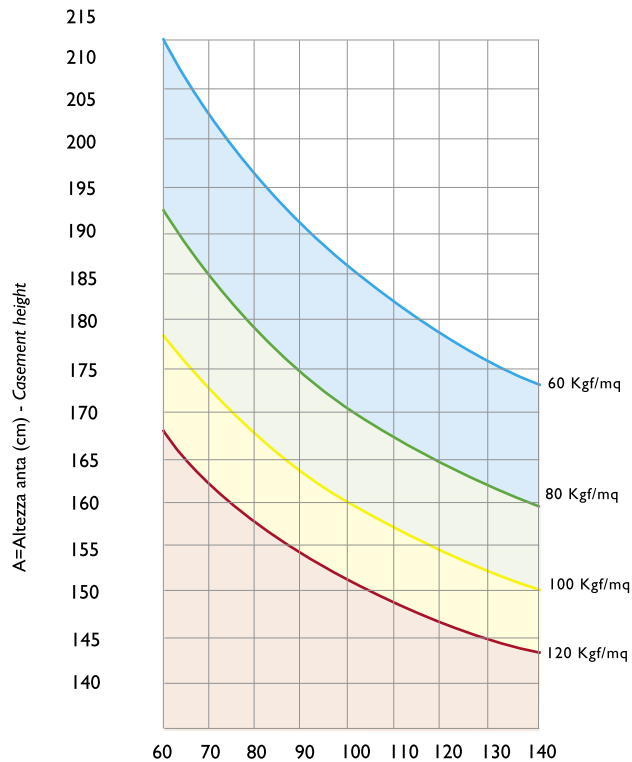

L=Larghezza anta (cm) - Casement width

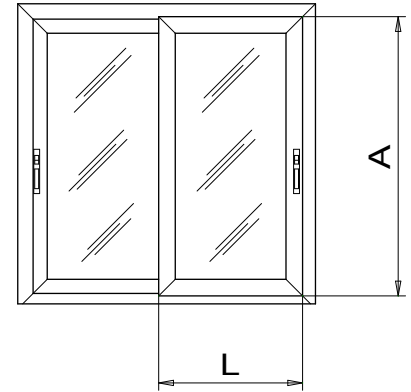

Carico del vento:
Wind load:
60 Kg/mq

L	A
60	211,47
70	201,97
80	194,48
90	188,52
100	183,77
110	180,01
120	177,06
130	174,81
140	173,16

Carico del vento:
Wind load:
80 Kg/mq

L	A
60	192,58
70	184,13
80	177,54
90	172,38
100	168,35
110	165,24
120	162,90
130	161,22
140	160,11

Carico del vento:
Wind load:
100 Kg/mq

L	A
60	179,15
70	171,46
80	165,53
90	160,95
100	157,44
110	154,82
120	152,93
130	151,68
140	150,97

Carico del vento:
Wind load:
120 Kg/mq

L	A
60	168,92
70	161,82
80	156,40
90	152,27
100	149,18
110	146,93
120	145,40
130	144,50
140	144,09

LIMITI D' IMPIEGO - LIMITS OF USE

FRECCIA MASSIMA - MAXIMUM CAMBER: 1/200

ZN7-32016

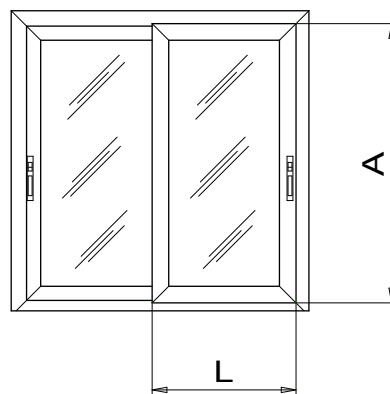
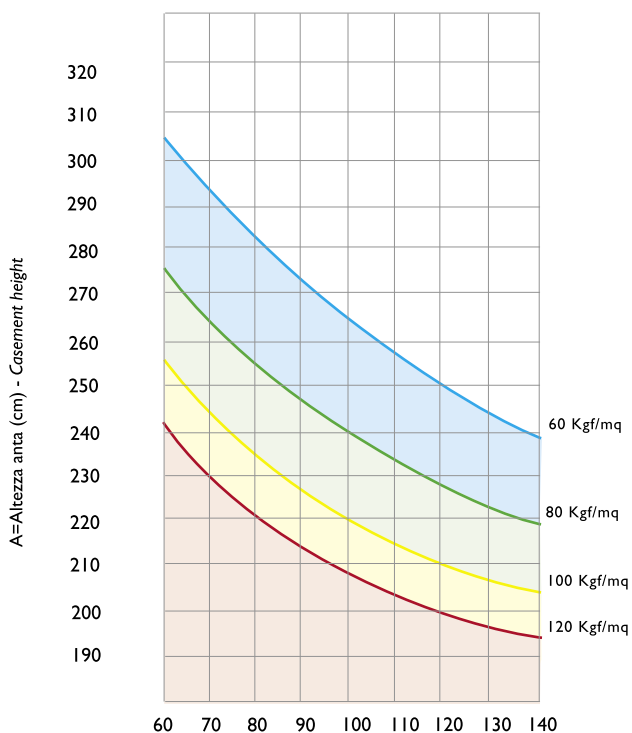

L=Larghezza anta (cm) - Casement width

Carico del vento:
Wind load:
60 Kgf/mq

L	A
60	305,18
70	290,65
80	278,91
90	269,25
100	261,20
110	254,44
120	248,75
130	243,95
140	239,92

Carico del vento:
Wind load:
80 Kgf/mq

L	A
60	277,59
70	264,52
80	254,01
90	245,41
100	238,30
110	232,39
120	227,48
130	223,40
140	220,04

Carico del vento:
Wind load:
100 Kgf/mq

L	A
60	257,96
70	245,93
80	236,31
90	228,48
100	222,06
110	216,77
120	212,42
130	208,87
140	206,01

Carico del vento:
Wind load:
120 Kgf/mq

L	A
60	242,98
70	231,76
80	222,82
90	215,59
100	209,69
110	204,89
120	200,99
130	197,85
140	195,38



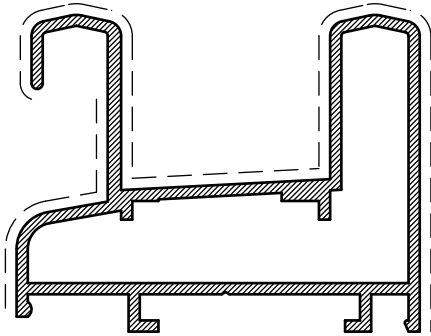

zn7-32001

gr/m 1003

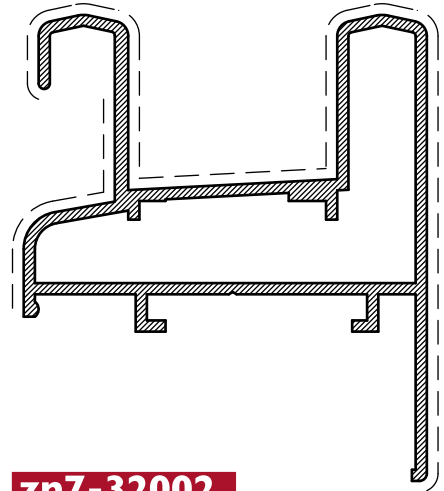

zn7-32002

gr/m 1084

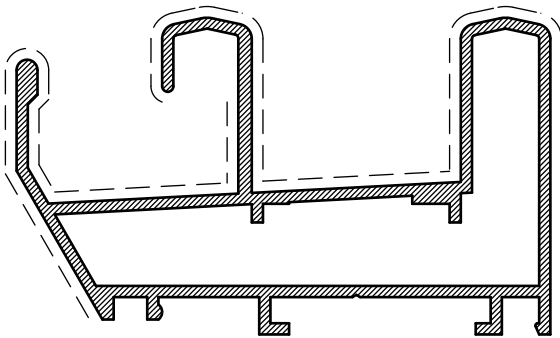

zn7-32003

gr/m 1224

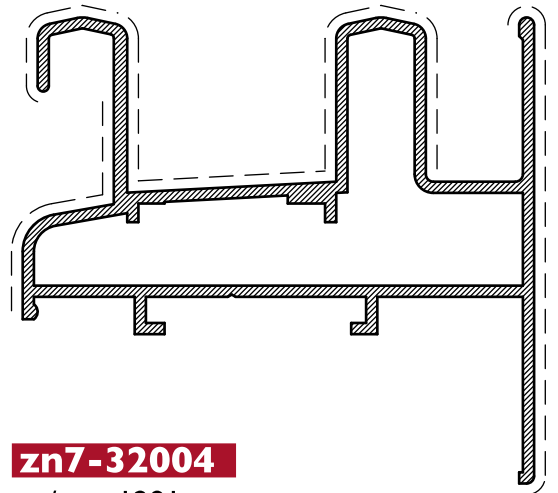

zn7-32004

gr/m 1291

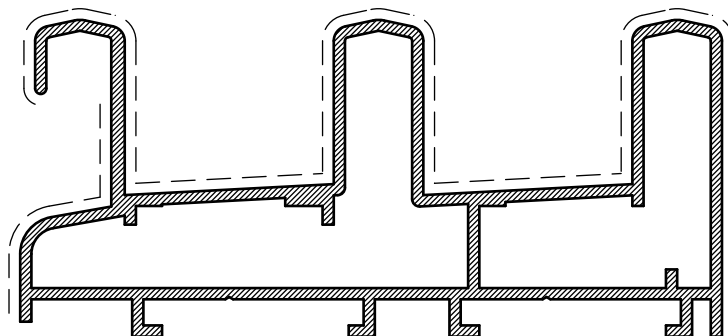

zn7-32005

gr/m 1621

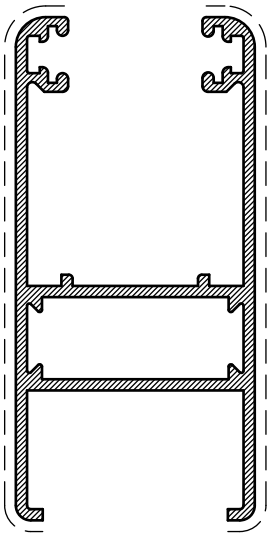

zn7-32015
gr/m 944

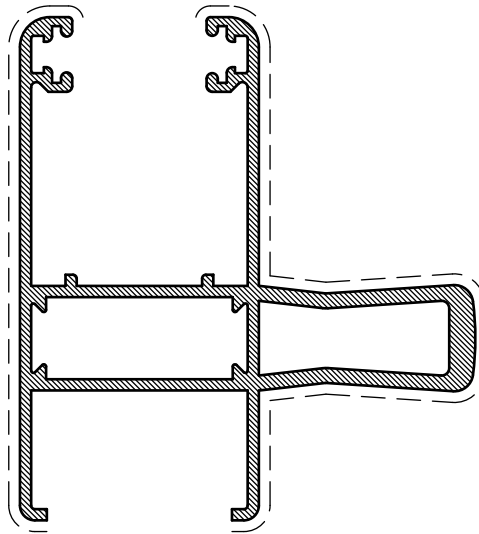

zn7-32016
gr/m 1342

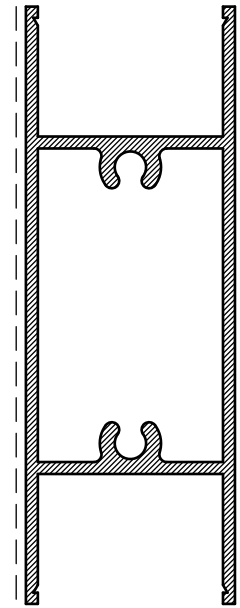

G56
gr/m 1033

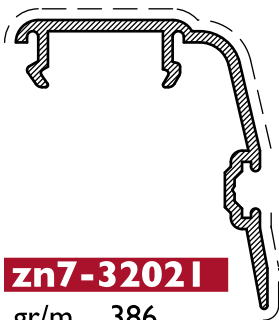

zn7-32021
gr/m 386

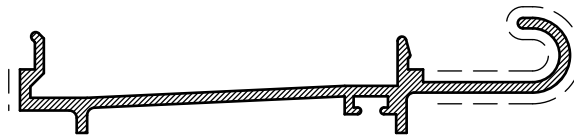

zn7-32010
gr/m 446

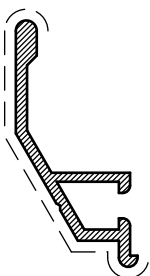

zn7-32025
gr/m 228

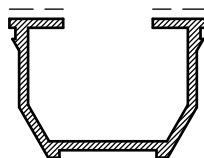

G91
gr/m 225

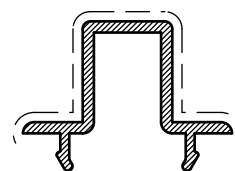

G87
gr/m 251

2
3

ADATTAMENTO A SERIE COMMERCIALI
FIT TO COMMERCIAL SERIES

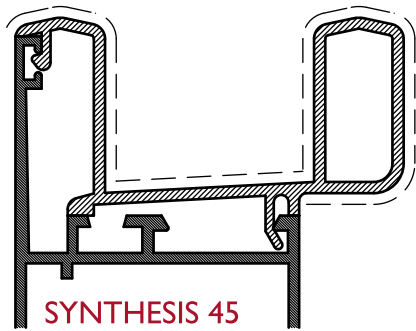

SYNTHESIS 45

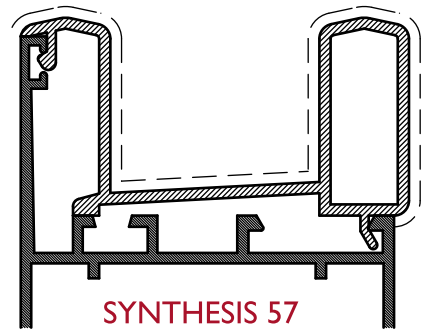

SYNTHESIS 57

zn7-32006

gr/m 577

zn7-32007

gr/m 585

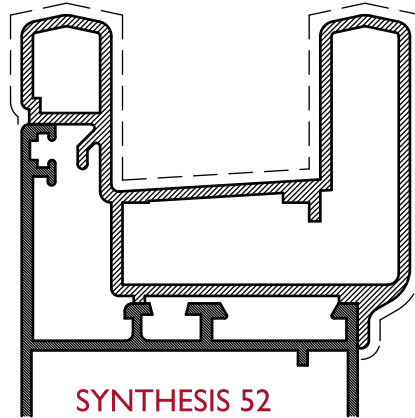

SYNTHESIS 52

zn7-32037

gr/m 910

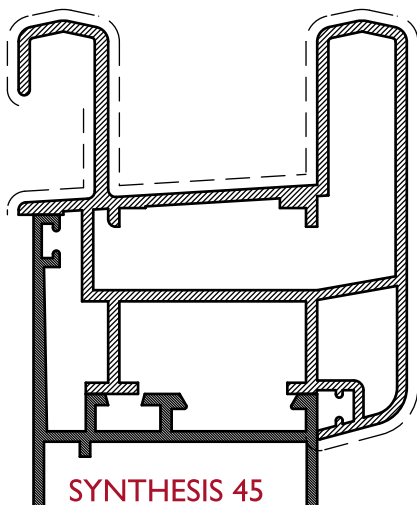

SYNTHESIS 45

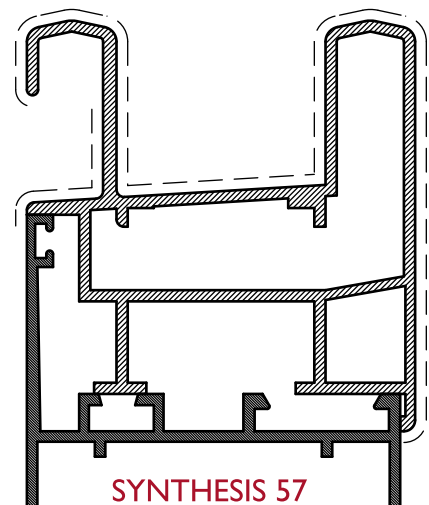

SYNTHESIS 57

zn7-32030

gr/m 1128

zn7-32032

gr/m 1114

ADATTAMENTO A SERIE COMMERCIALI
FIT TO COMMERCIAL SERIES

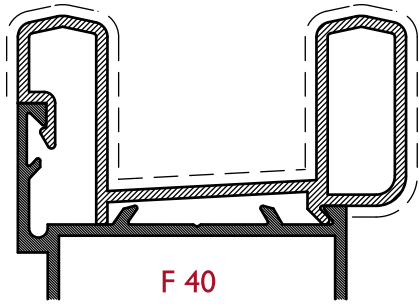

F 40

zn7-32008

gr/m 615

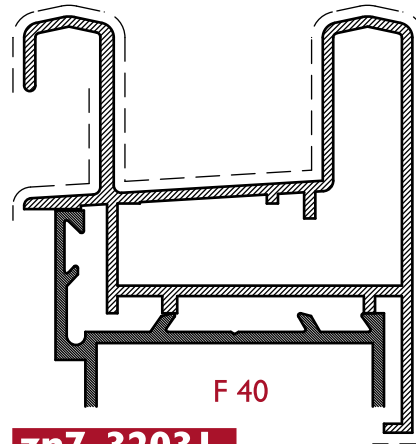

F 40

zn7-32031

gr/m 906

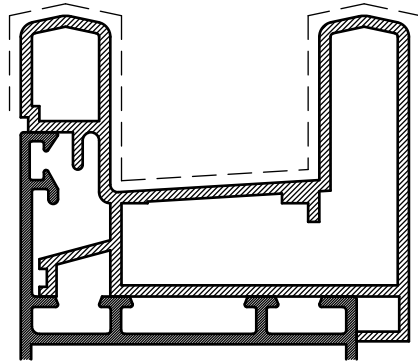

R 40

zn7-32035

gr/m 959

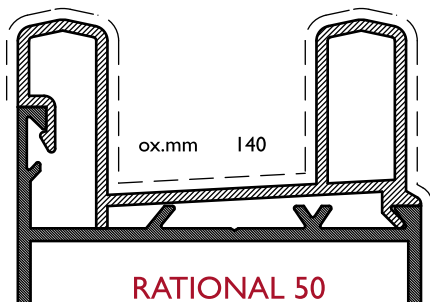

RATIONAL 50

zn7-32009

gr/m 622

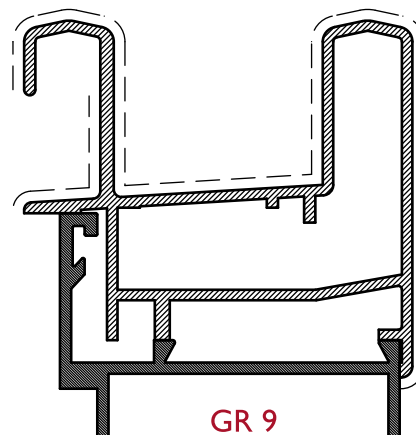

GR 9

zn7-32033

gr/m 900

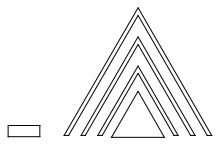

alu-mec

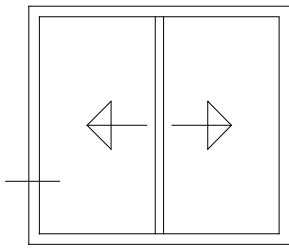

NODO LATERALE FINESTRA E PORTA FINESTRA
CON GUIDA ZANZARIERA

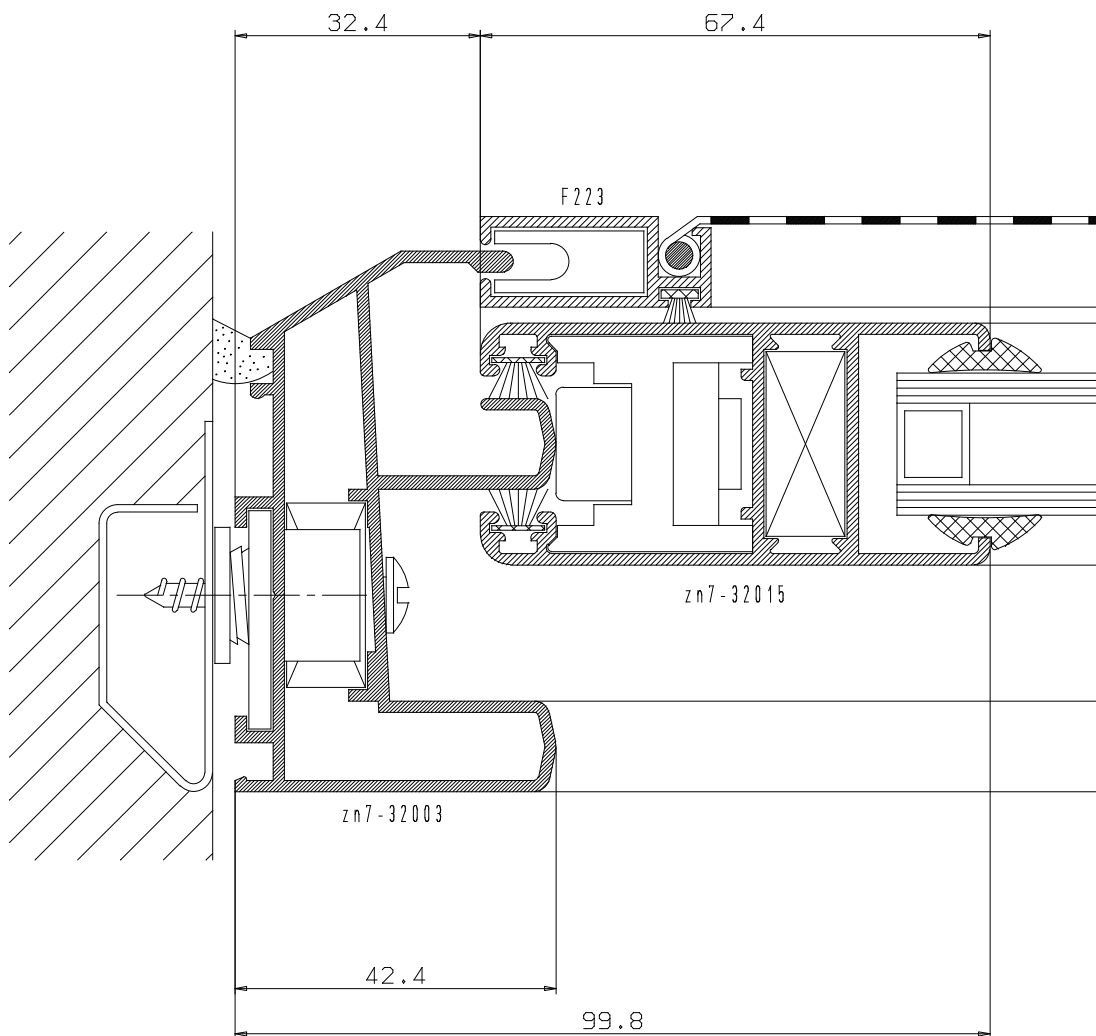

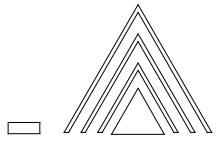

alu-mec

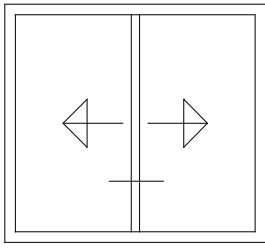

NODO CENTRALE FINESTRA
E PORTA/FINESTRA

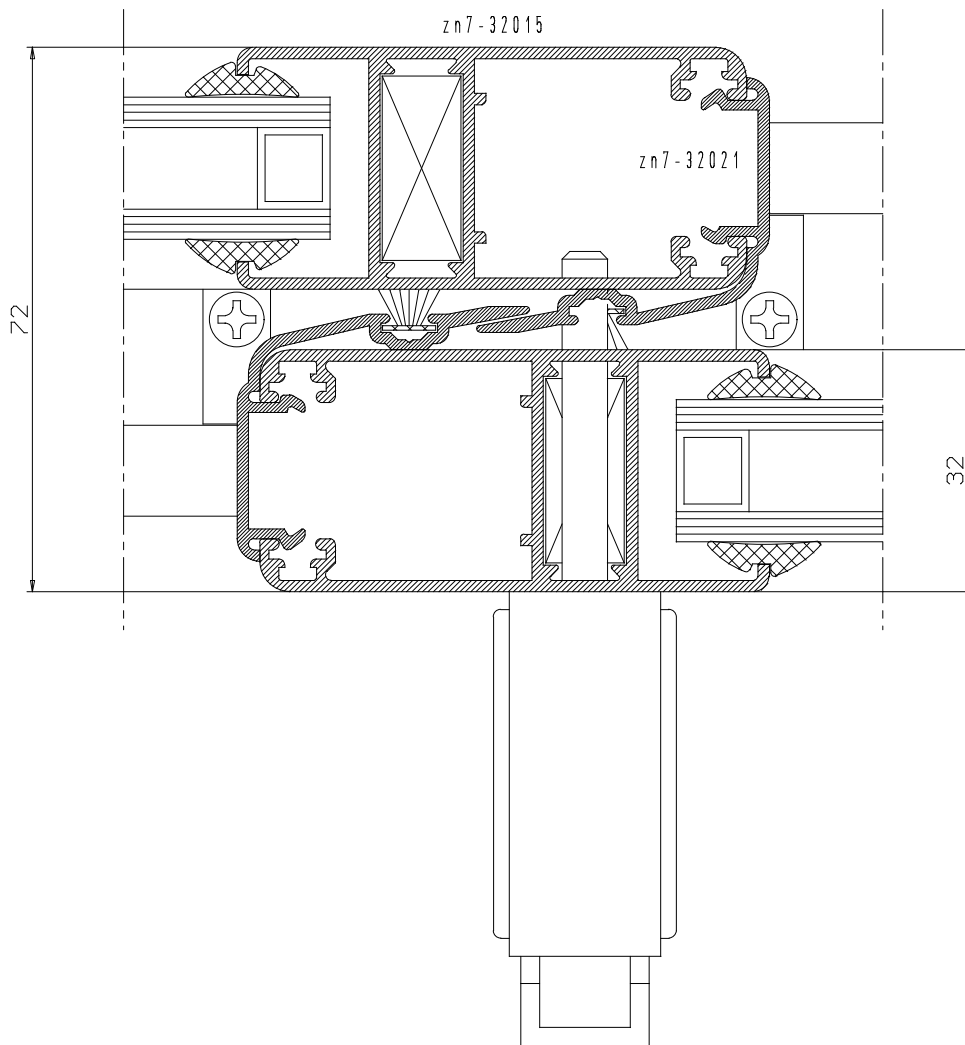

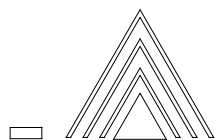

alu-mec

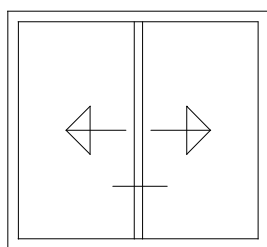

NODO CENTRALE FINESTRA
E PORTA/FINESTRA CON ZANZARIERA

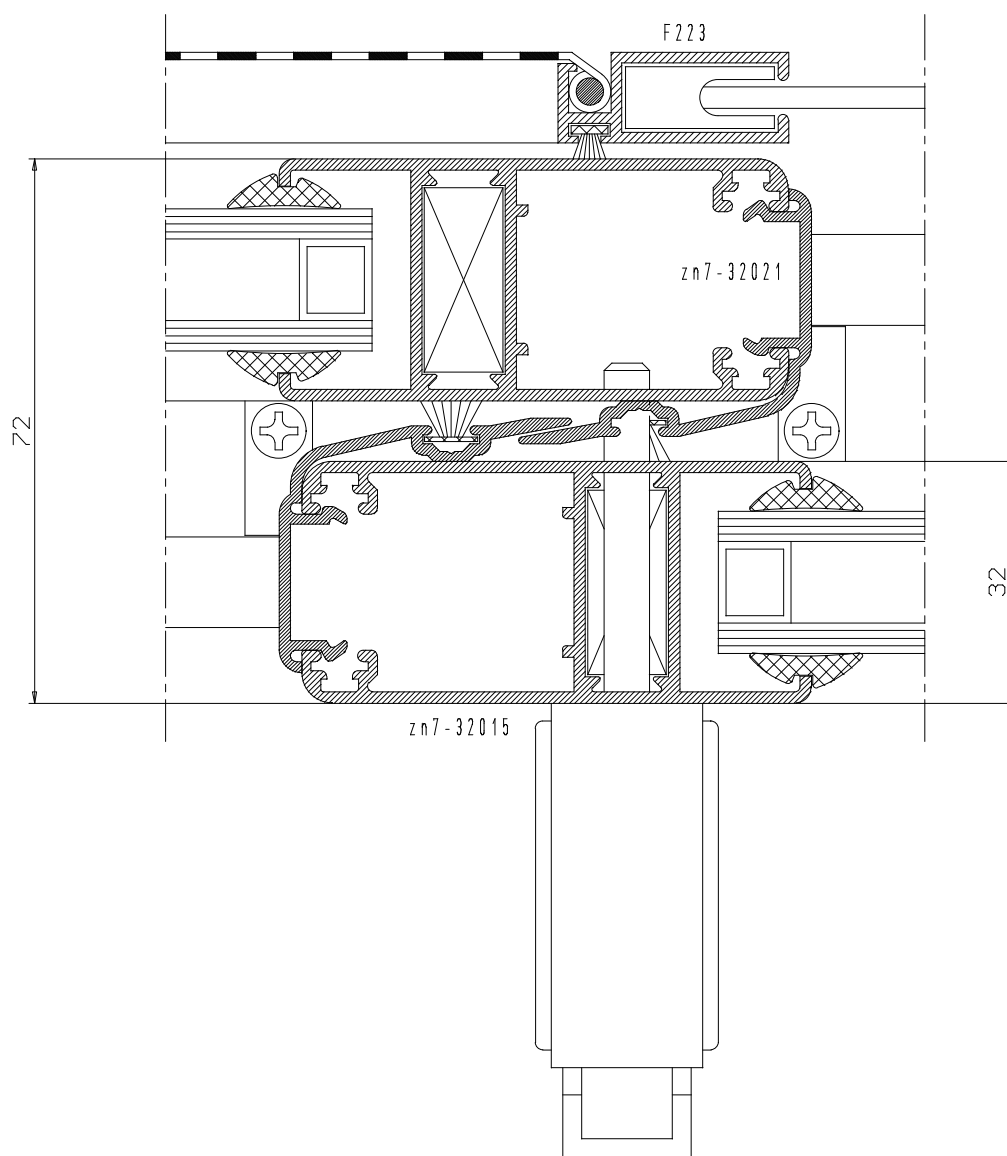

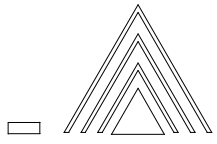

alu-mec

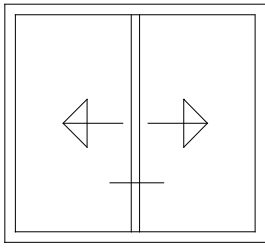

NODO CENTRALE FINESTRA
E PORTA/FINESTRA (zn7-32016)

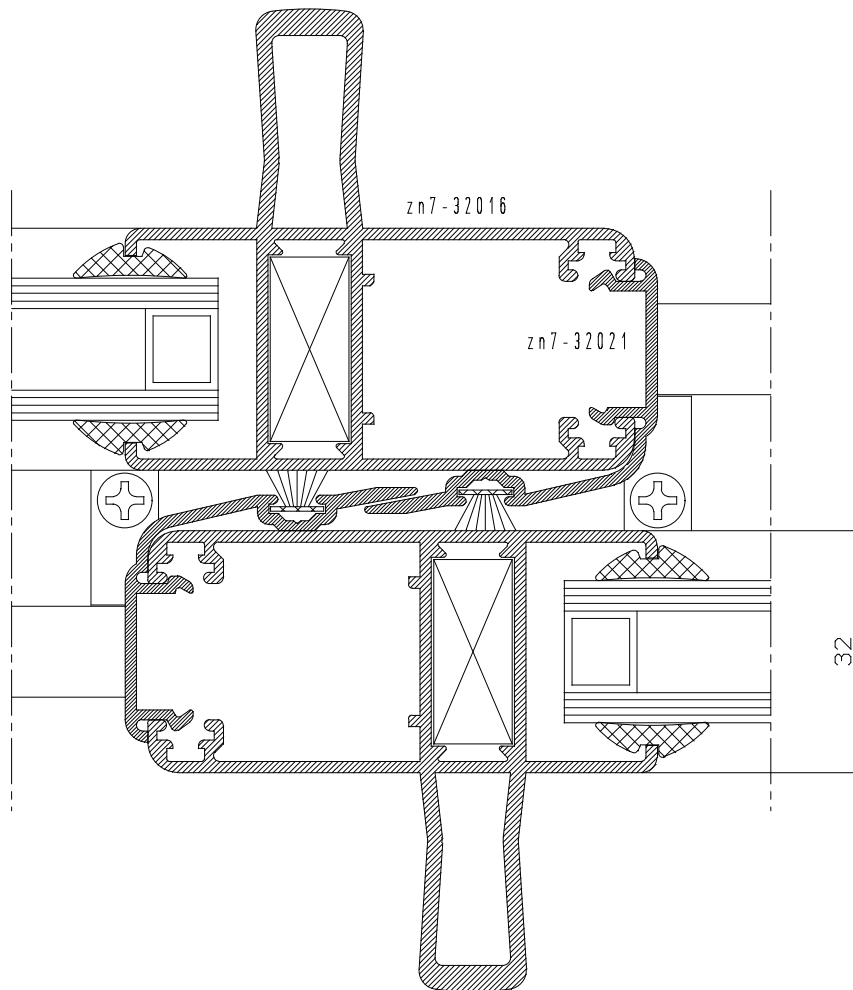

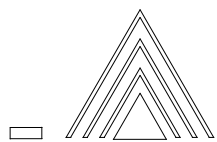

alu-mec

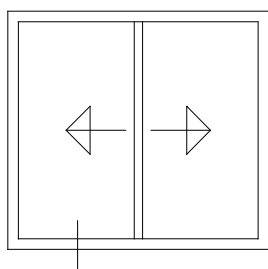

NODO INFERIORE FINESTRA
E PORTA/FINESTRA

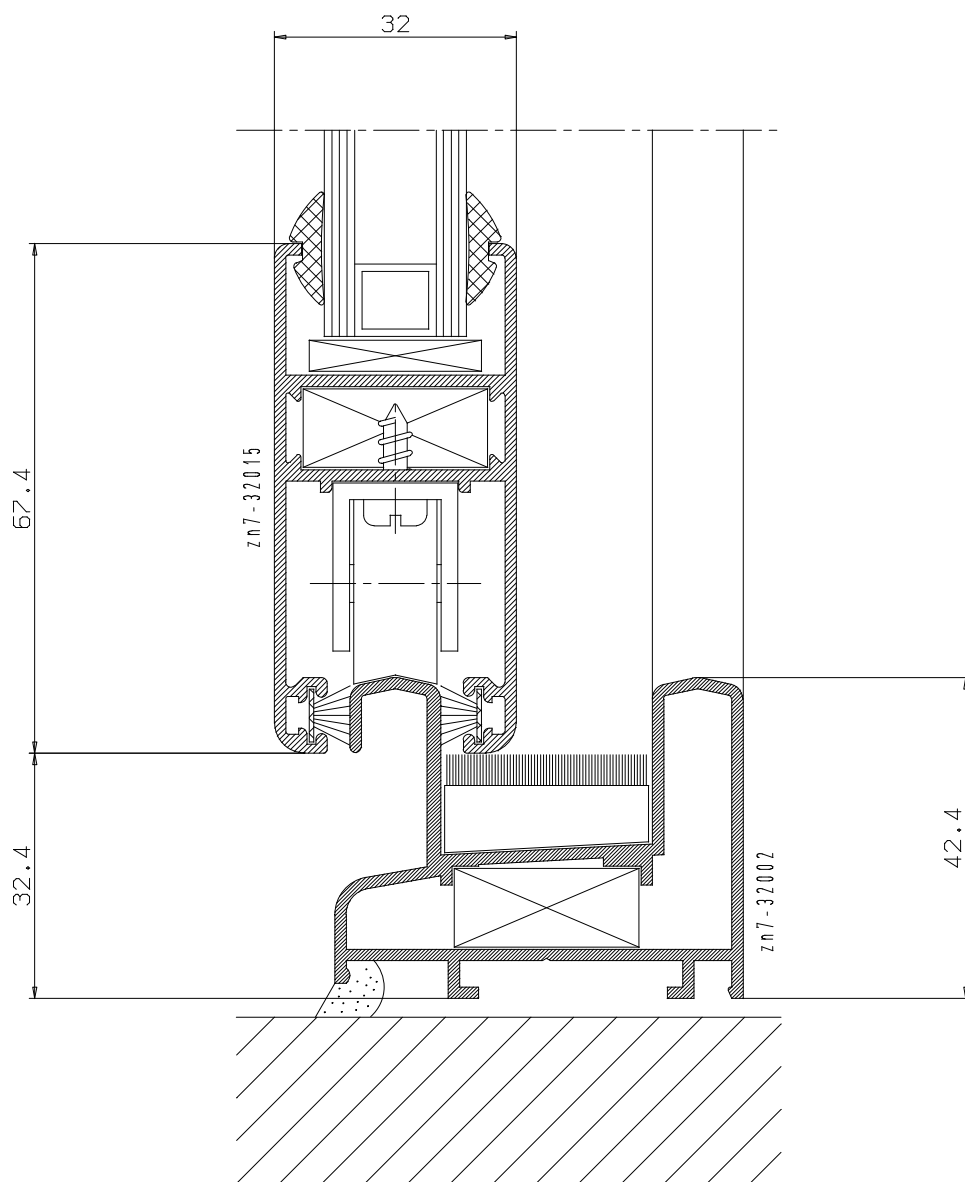

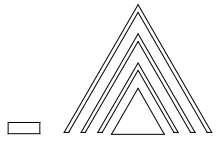

alu-mec

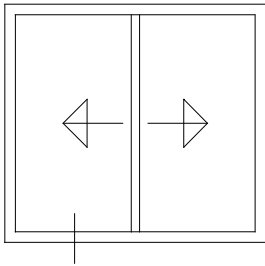

NODO INFERIORE FINESTRA E PORTA-FINESTRA
CON GUIDA PER ZANZARIERA

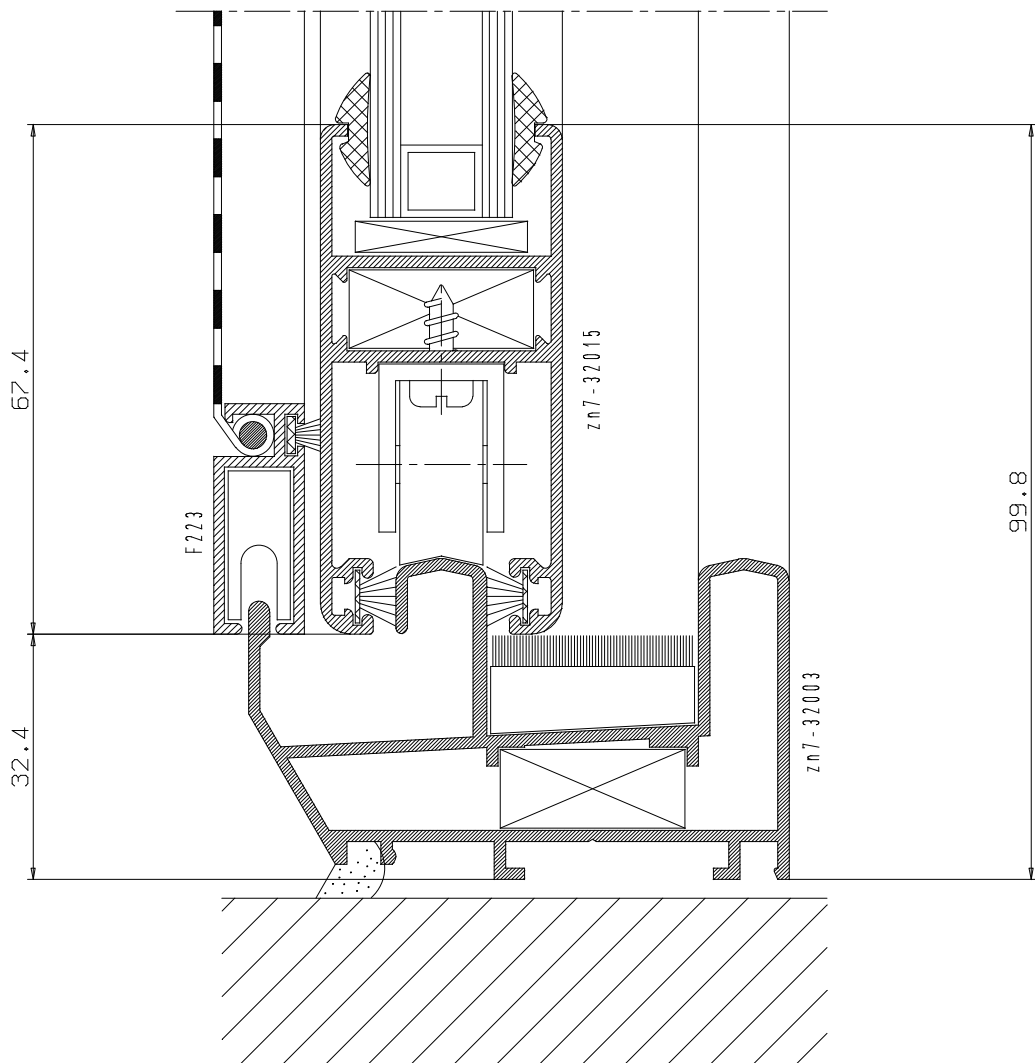

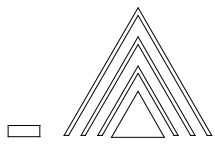

alu-mec

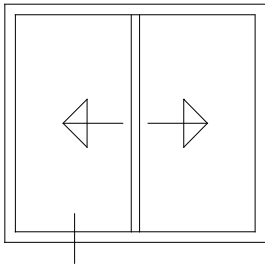

NODO INFERIORE FINESTRA E PORTA-FINESTRA
CON RACCOGLI-CONDENSA

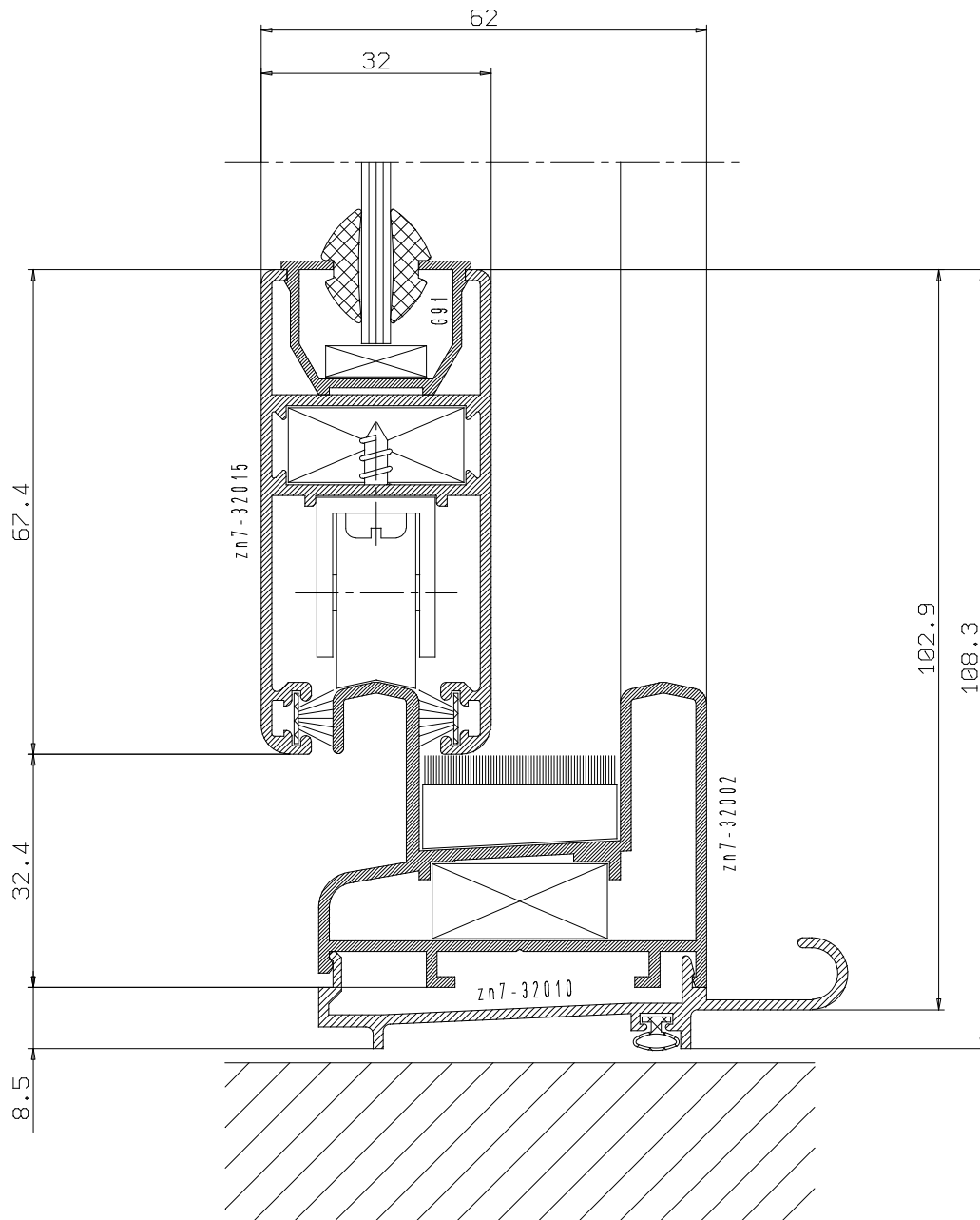

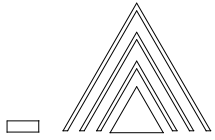

alu-mec

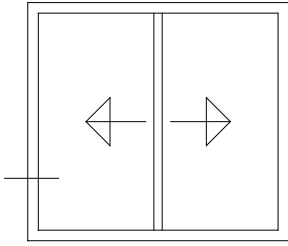

NODO LATERALE FINESTRA
E PORTA/FINESTRA

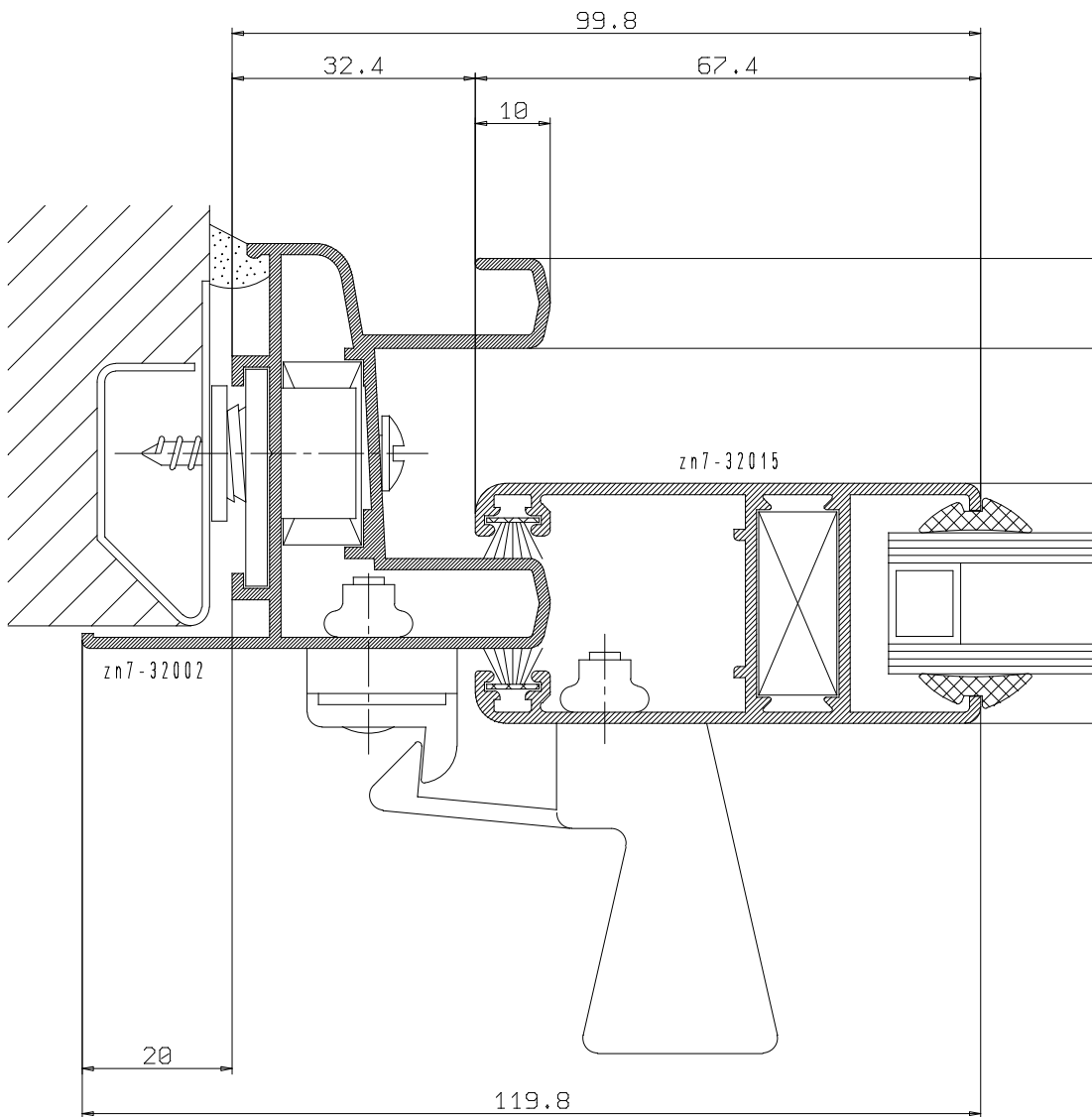

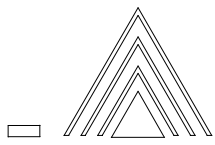

alu-mec

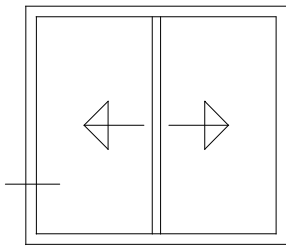

NODO LATERALE FINESTRA
E PORTA/FINESTRA A TRE VIE

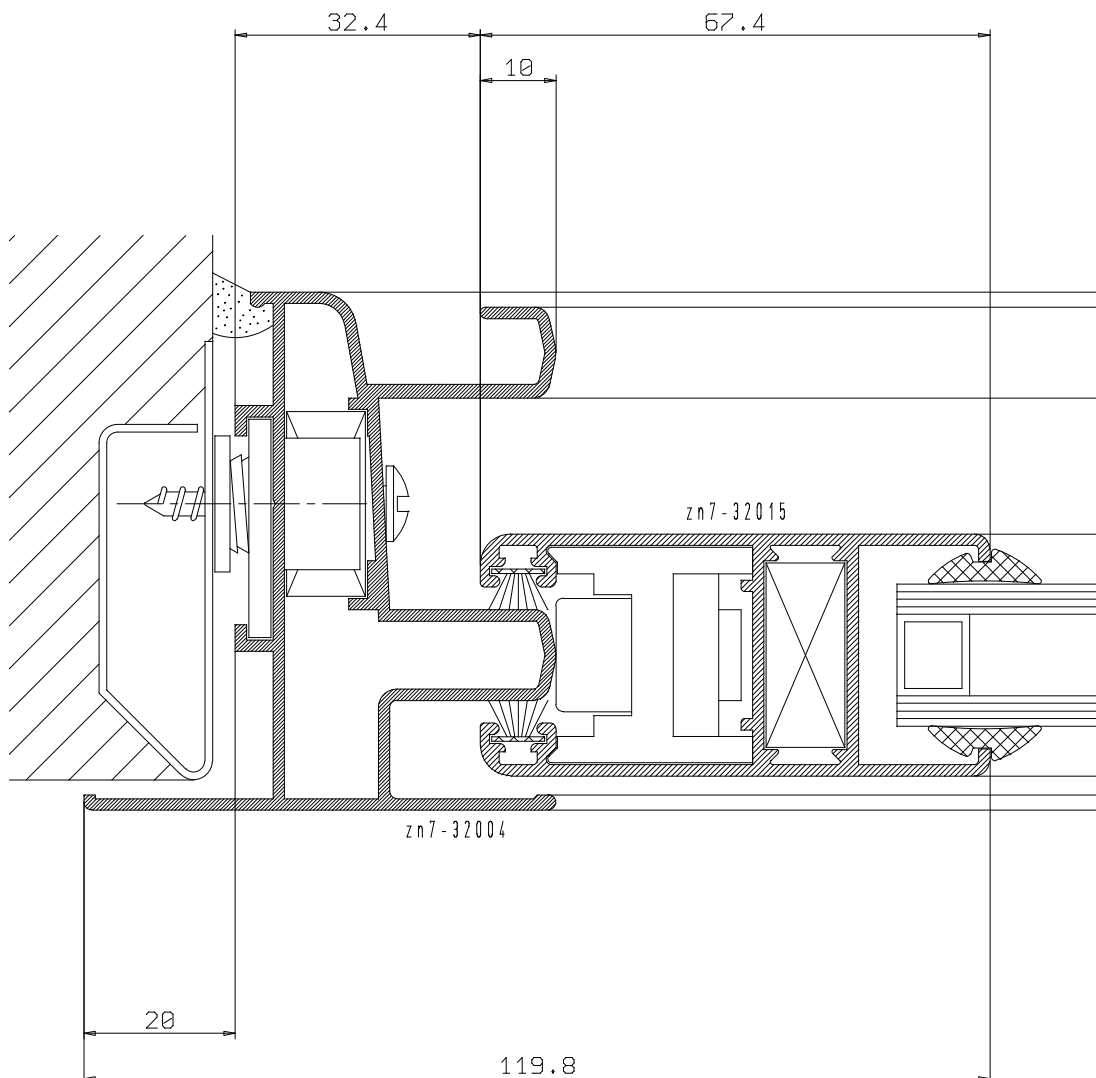

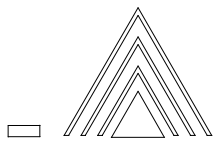

alu-mec

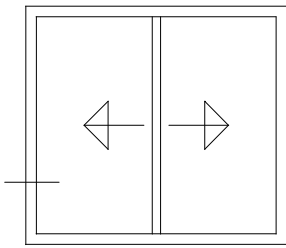

NODO LATERALE FINESTRA
E PORTA/FINESTRA (zn6-32004)

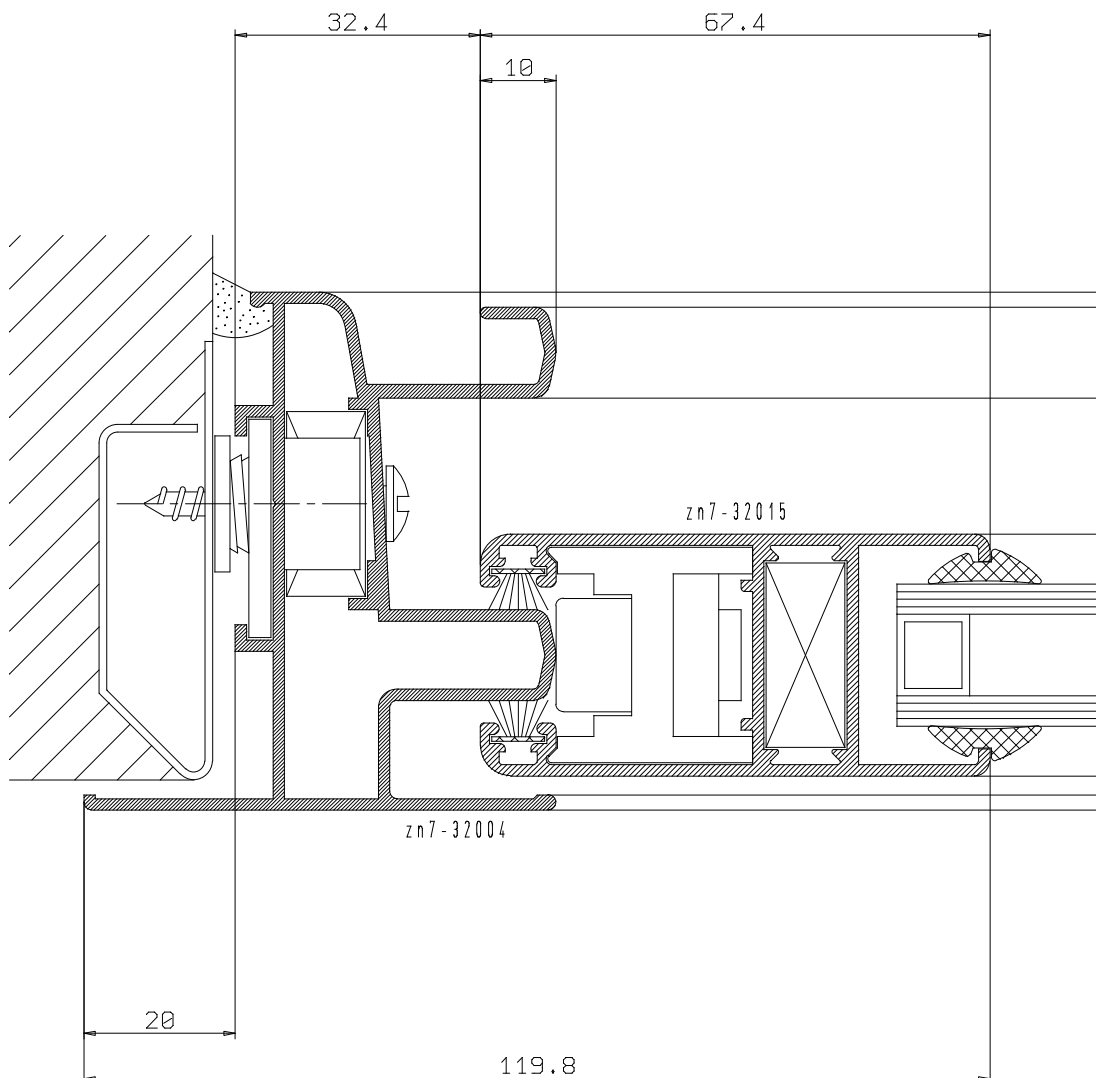

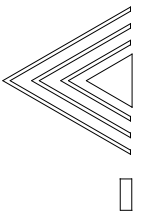

alu-mec

PORTA FINESTRA A DUE ANTE

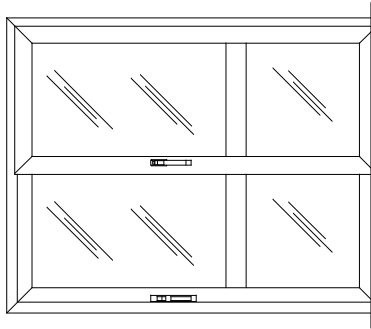

articolo	taglio	n° pezzi
zn7-32001		2
zn7-32001		2
zn7-32015		4
zn7-32015		4
zn7-32021		2
G56		2

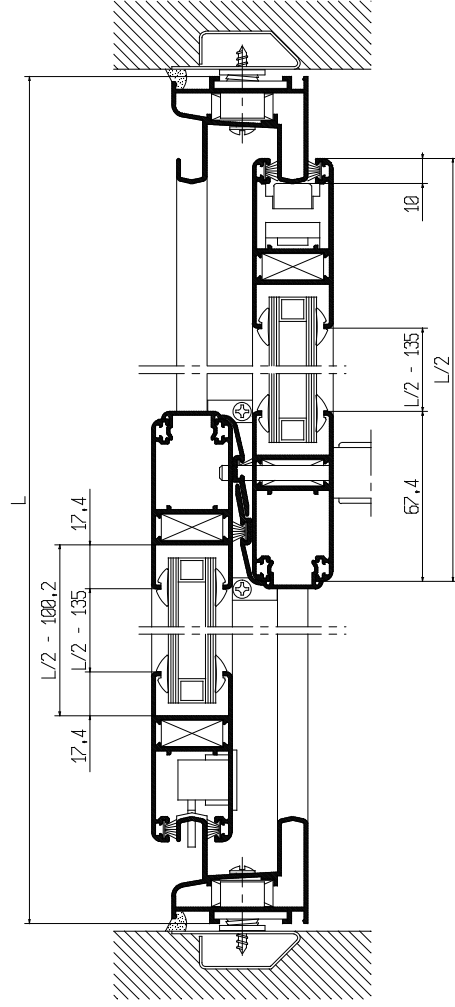
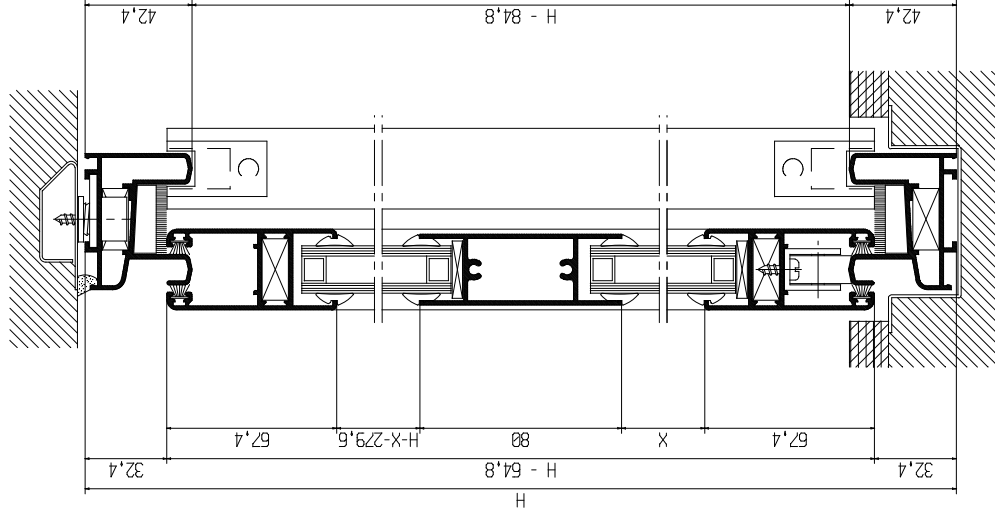

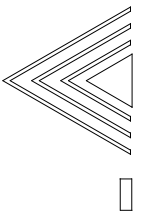

alu-mec

FINESTRA A DUE ANTE

- adattamento alla serie F 40 -

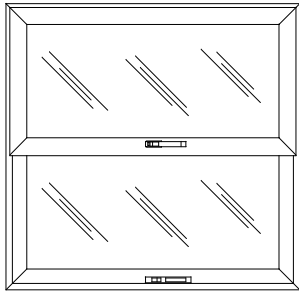

articolo	taglio	n° pezzi
zn7-32008		2
zn7-32008		2
zn7-32015		4
zn7-32015		4
zn7-32021		2

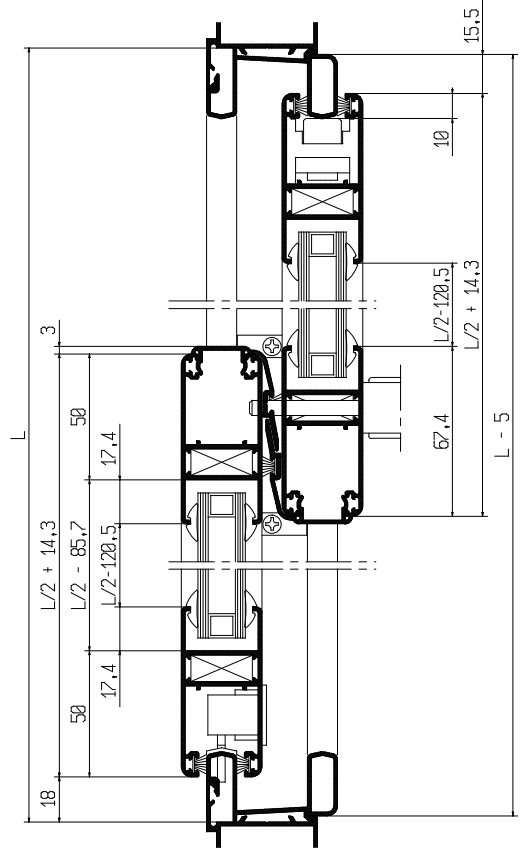
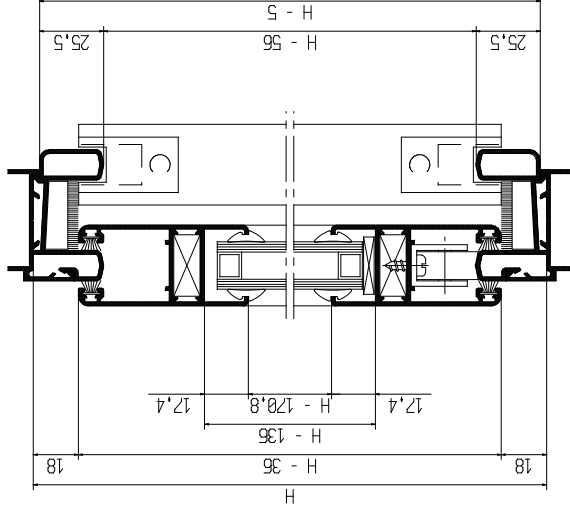

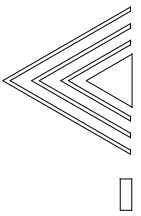

alu-mec

FINESTRA A DUE ANTE

- adattamento alla serie SYNTHESIS 45 -

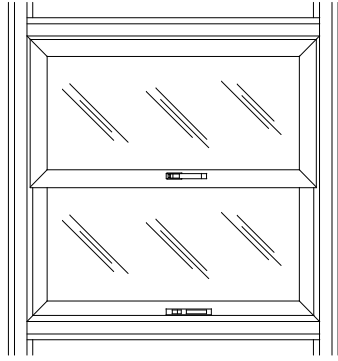

articolo	taglio	n° pezzi
zn7-32006		2
zn7-32006		2
zn7-32015		4
zn7-32015		4
zn7-32021		2

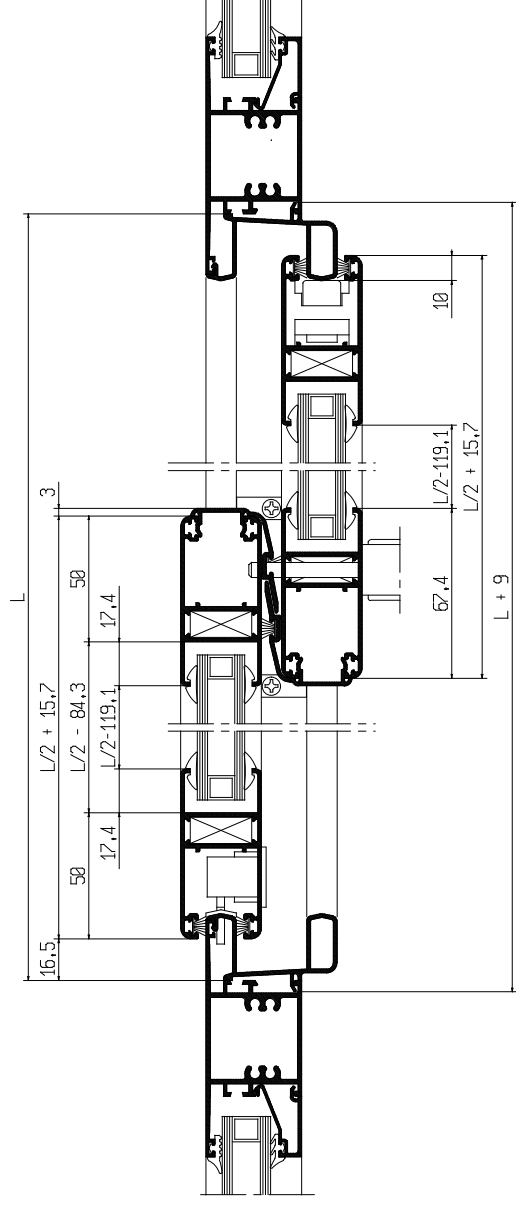
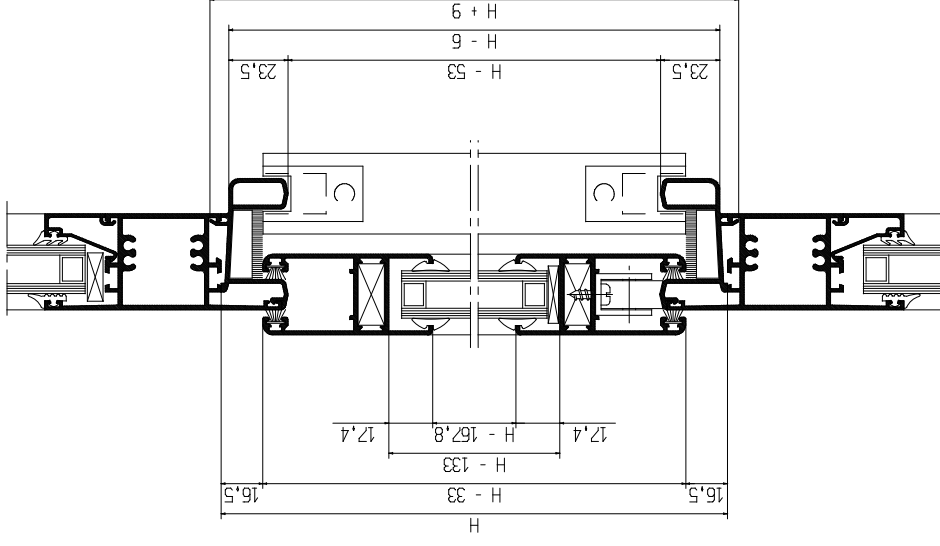

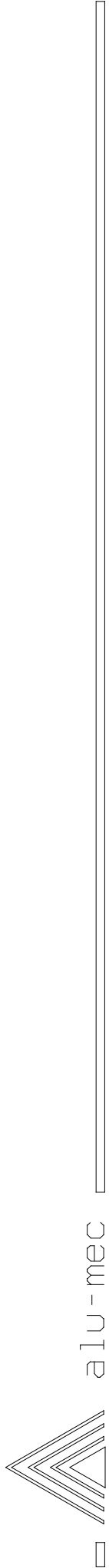

FINESTRA A DUE ANTE

- adattamento alla serie SYNTHESIS 57 -

articolo	taglio	n° pezzi
zn7-32007		2
zn7-32007		2
zn7-32015		4
zn7-32015		4
zn7-32021		2

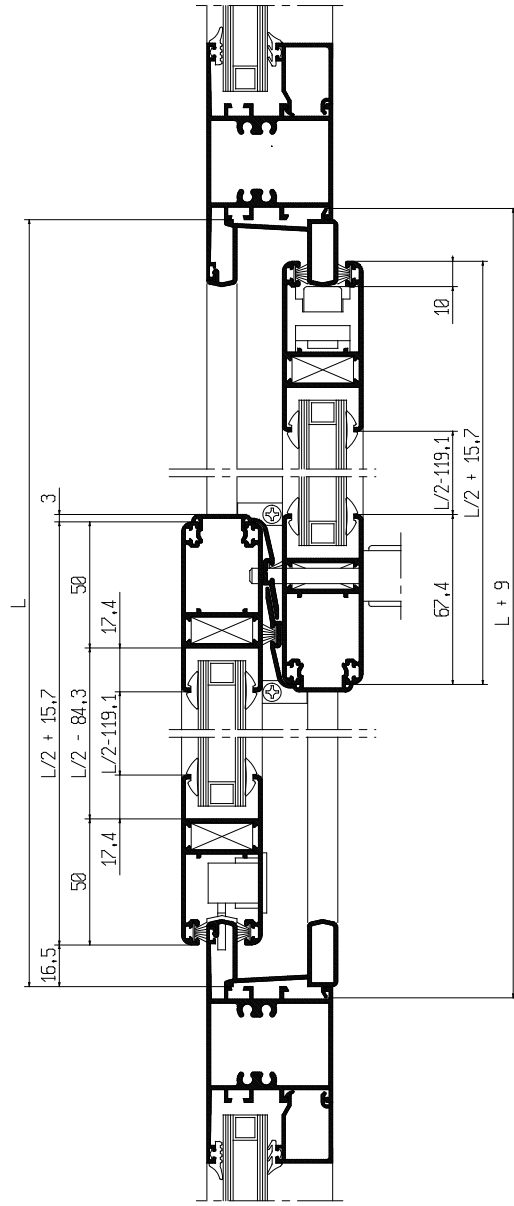
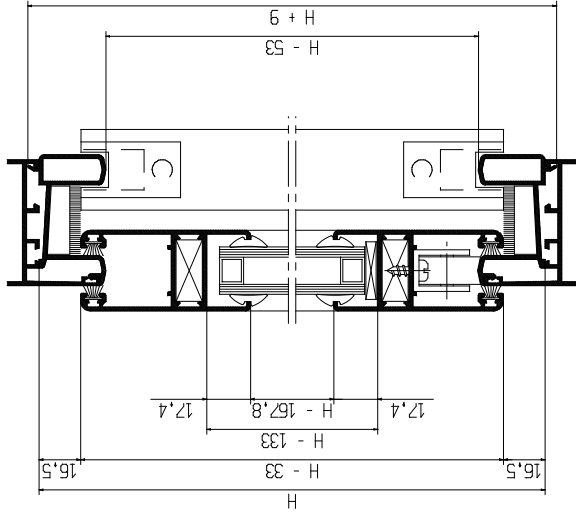
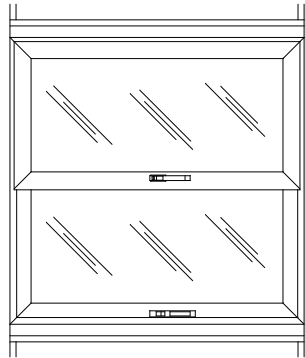

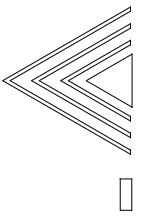

alu-mec

FINESTRA A DUE ANTE
- con guida per zanzariera -

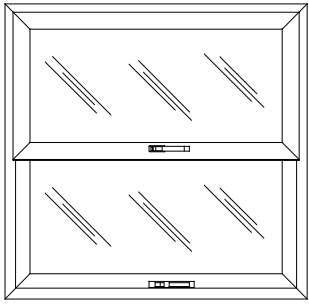

articolo	taglio	n° pezzi
zn7-32003		2
zn7-32003		2
zn7-32015		4
zn7-32015		4
zn7-32021		2
F223		2
F223		2

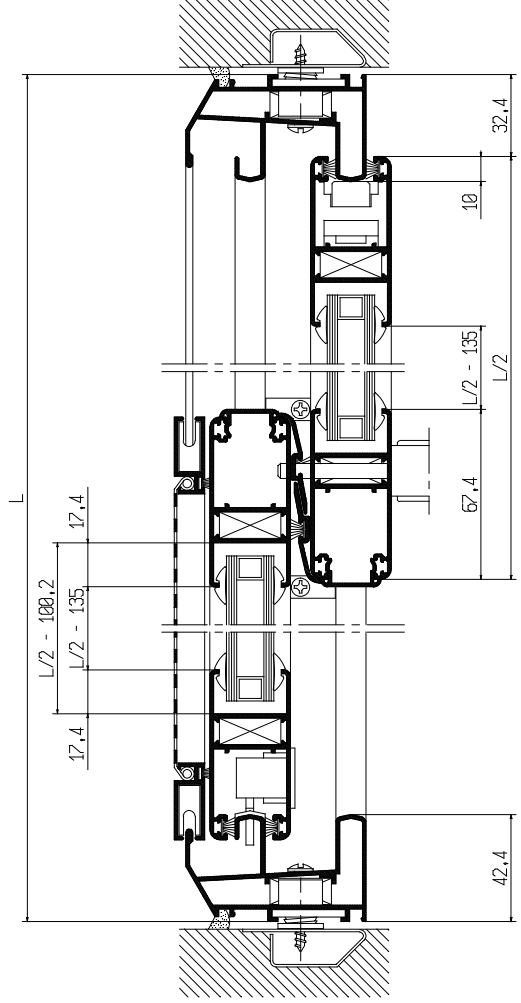
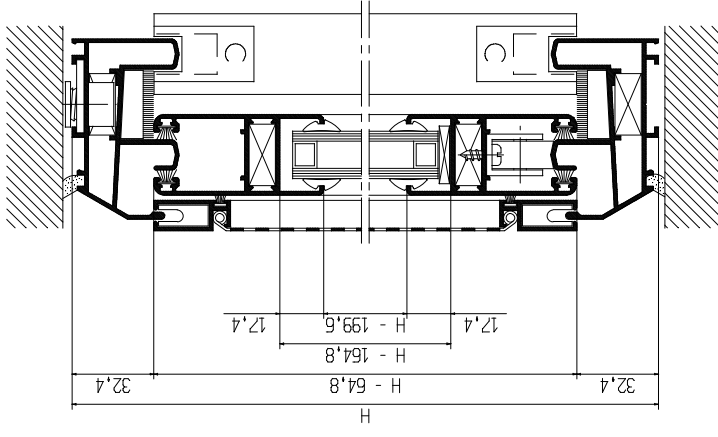

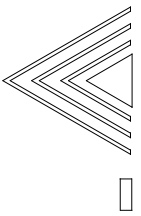

alu-mec

FINESTRA A QUATTRO ANTE

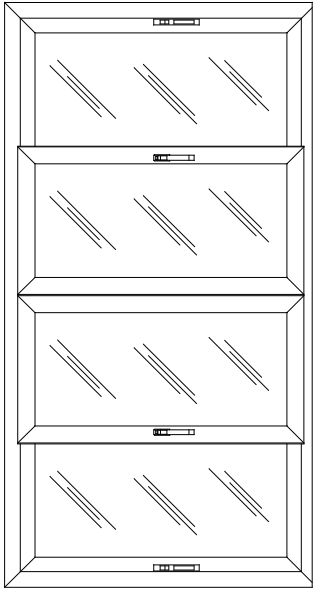

articolo	taglio	n° pezzi
zn7-32002		1
zn7-32002		2
zn7-32001		1
zn7-32015		8
zn7-32015		8
zn7-32021		4
G87		1

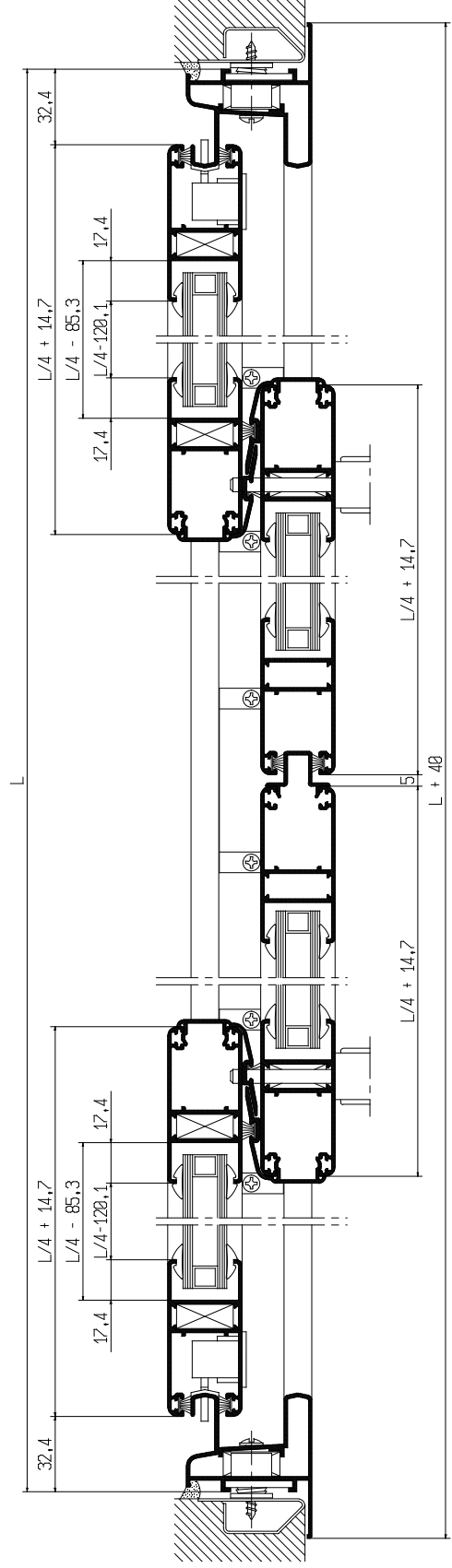
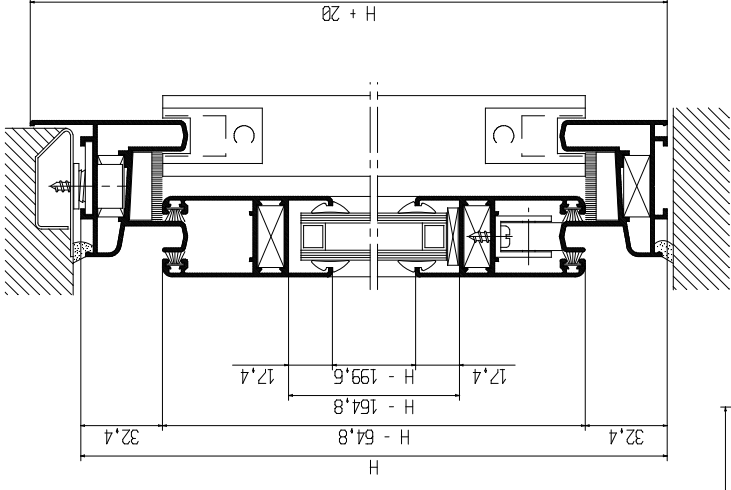

FINESTRĂ ÎN TRE ANTE

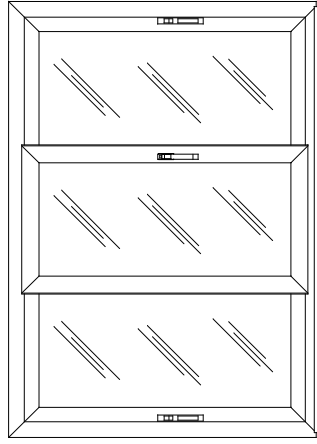

articol	taglio	n° pezzi
ZN7-32002		1
ZN7-32002		2
ZN7-32001		1
ZN7-32015		6
ZN7-32015		6
ZN7-32021		4
ZN7-32010		1

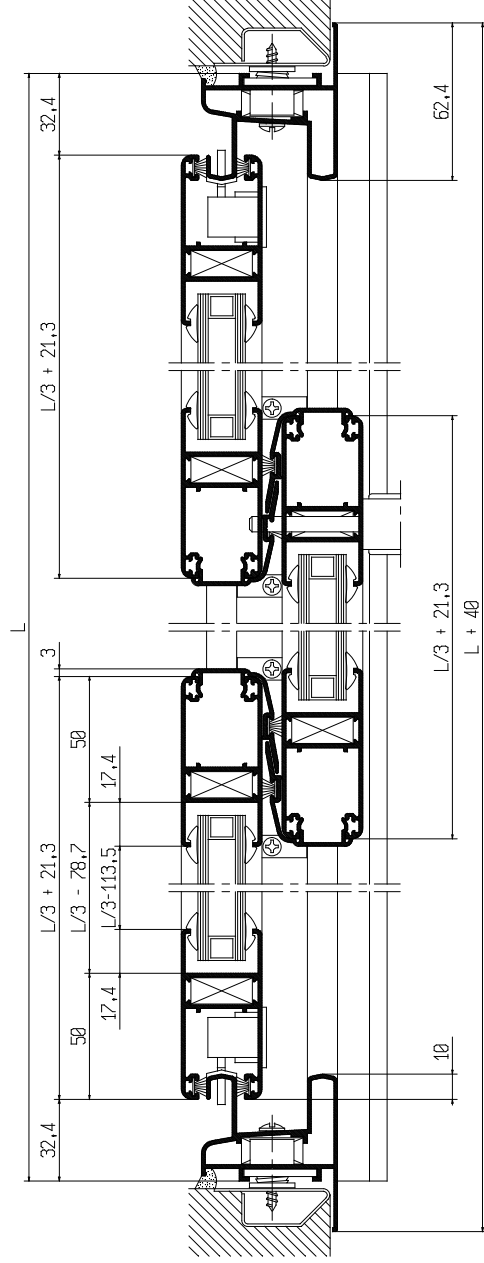
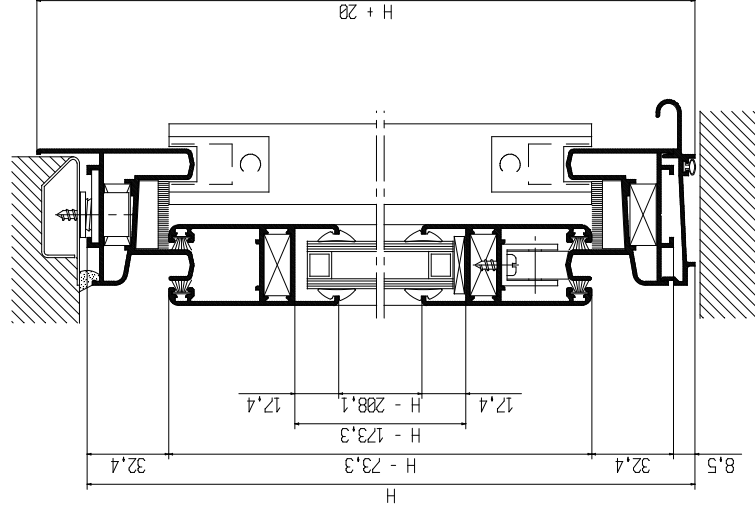

FINESTRA A TRE ANTE

- con binario a tre vie -

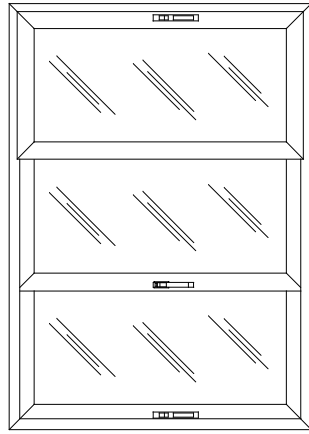

articolo	taglio	n° pezzi
ZN7-32005		2
ZN7-32005		2
ZN7-32015		6
ZN7-32015		6
ZN7-32021		4
G91		6
G91		6

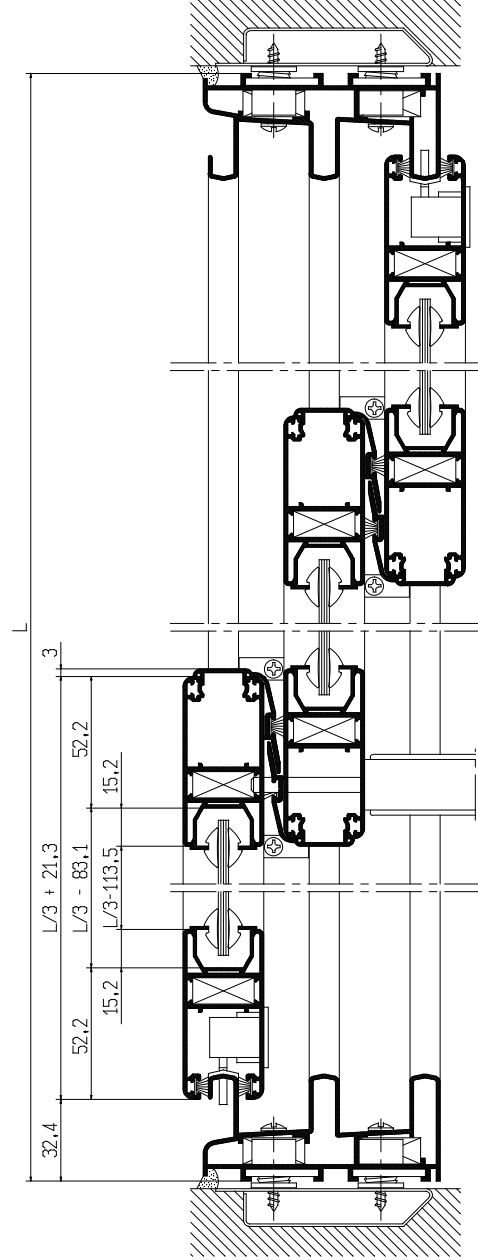
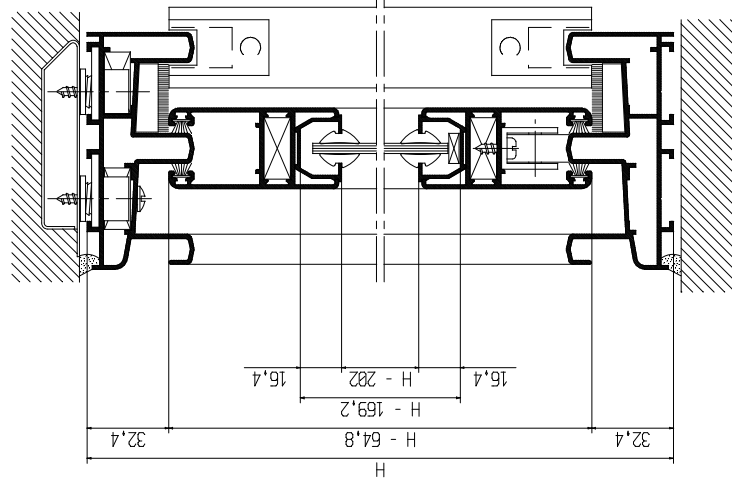

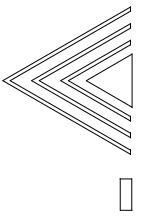

alu-mec

FINESTRÀ A DUE ANTE

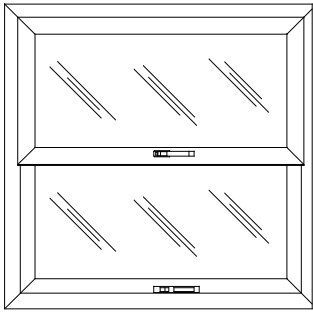

articolo	taglio	n° pezzi
zn7-32002		1
zn7-32002		2
zn7-32001		1
zn7-32015		4
zn7-32015		4
zn7-32021		2

